

## Unit FE-5 Foundation Electricity: Electrical Machines

### What this unit is about

Power networks consist of large number of interconnected hardware. This unit deals specifically with two types of hardware: transformers and electromechanical generators. Transformers use the mutual induction principles to step-up and step-down voltages for efficient power transmission from generators to consumers. The operating principles of transformers are discussed and their equivalent circuit derived. Constructional and operational details complete the picture. Machines that convert mechanical to electrical power are based on the principles of electromagnetics. These principles are used to describe the production of a Rotating Magnetic Field (RMF), the basis of operation of both synchronous and induction machines. The properties of the RMF are then used to describe the operational characteristics and limitations of a synchronous generator. This is followed by an explanation of how, in induction machines, rotor currents are generated through induction by virtue of the slip between the stator RMF and the rotor speed.

### Why is this knowledge necessary?

Renewable energy sources are used mainly to generate AC electrical power, which is injected into power networks consisting of large number of transmission lines, transformers and other conventional generators and consumers. Such power networks, especially in developed countries, are of considerable complexity. To determine the way these injected powers flow from generators to consumers requires complex calculations based on network analysis. This unit introduces the basic concepts of the electrical machines that are found in power networks. Transformers are used in all but the most primitive networks to step-up or -down transmission network voltages for efficient operation. The knowledge of the transformer equivalent circuit is essential to perform power system analysis studies. There are two types of generators (synchronous and asynchronous) for the conversion of mechanical into electrical energy. Knowledge of the basic operating principles of these generators is essential to appreciate their advantages and limitations when used in renewable energy conversion systems.

***At the beginning of each section the course module(s) that requires the material in this particular section as background knowledge are indicated in bold italics. All sections of this unit are required as background material for Unit FE-5.***

# Contents

	<b>Page No.</b>
<b>1. The Transformer</b>	<b>3</b>
<b>1.1 Introduction</b>	<b>3</b>
<b>1.2 Principle of Operation of the Transformer</b>	<b>4</b>
<b>1.3 The Non-ideal Transformer and its Equivalent Circuit</b>	<b>5</b>
<b>1.4 Further Details on Transformers</b>	<b>6</b>
<b>2. The Synchronous Machine</b>	<b>8</b>
<b>2.1 Basic Constructional Characteristics</b>	<b>8</b>
<b>2.2 The Rotating Magnetic Field</b>	<b>9</b>
<b>2.3 The Mode of Operation of the Synchronous Machine</b>	<b>10</b>
<b>3. The Induction Machine</b>	<b>12</b>
<b>3.1 Construction</b>	<b>12</b>
<b>3.2 Mode of Operation</b>	<b>13</b>
<b>3.3 The Equivalent Circuit</b>	<b>15</b>

# 1. The Transformer

*[This material relates predominantly to module ELP032]*

## 1.1 Introduction

The principle of transformer operation has already been mentioned briefly in section 5, Unit FB-DC6 and section 1, Unit FE-3. There are two good reasons why it is important to investigate further the transformer's behaviour. The transformer is an indispensable part of any power system operating at a range of voltages and its action provides a useful understanding of the mode of operation of induction motors and generators. Induction generators are used extensively in modern grid connected wind turbines.

To recapitulate what has already been mentioned previously:

- Transformers consist of two or more coil windings coupled magnetically as in Fig 1 by way of low reluctance magnetic circuit (core)
- The source side winding is referred to as the primary side of the transformer
- The load side winding is referred to as the secondary side of the transformer.
- Usually (but not always) transformers step-up or step-down voltage, the windings can therefore be alternatively referred to as the High- (HV) or Low- (LV) voltage windings.

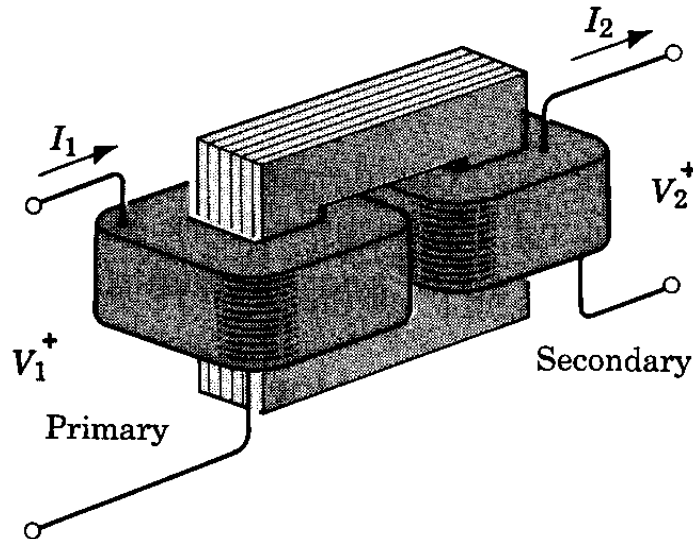
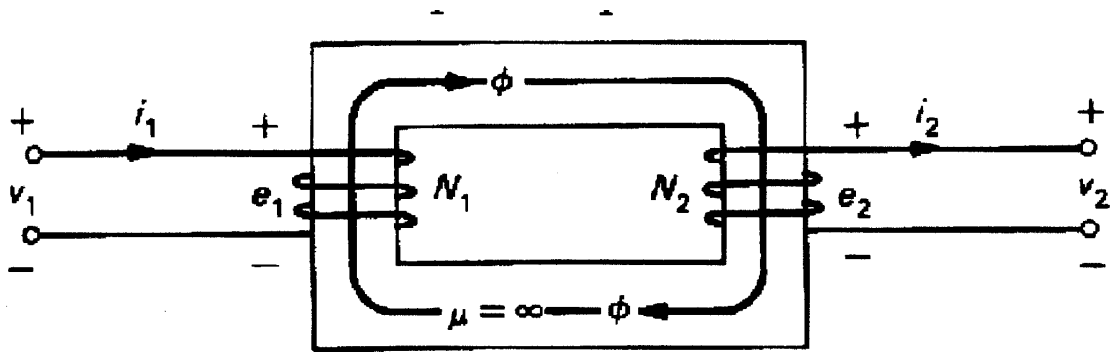

*Fig.1*

In what follows, some basic concepts of transformers will be discussed. The aim is not for the student to be able to solve circuit analysis problems involving transformers. Rather it is to introduce some ideas which are necessary in the understanding of the operation of induction generators.

## 1.2 Principle of Operation of the Transformer

The transformer of Fig 1 is shown diagrammatically in fig.2. For clarity, the windings in Figs 1 and 2 are shown on separate legs of the core but in practice, the two windings are placed close together so that they link virtually the same flux.



The induced voltages are, by Faraday's law,  $e_1 = N_1 d\phi/dt$  and  $e_2 = N_2 d\phi/dt$  (polarities governed by Lenz's law)

Under AC steady-state conditions, the RMS voltage phasors  $\mathbf{E}_1$  and  $\mathbf{E}_2$  are related by  $\mathbf{E}_1/\mathbf{E}_2 = N_1/N_2 = a$  where  $a$  is referred to as the voltage turns ratio.

*Fig. 2*

To determine the current ratio we may assume, to a very good approximation, that the transformer is perfect and lossless, in which case the input complex power will be identical to the output complex power. Hence:

$$S_1 = S_2, \quad (\mathbf{E}_1)(\mathbf{I}_1)^* = (\mathbf{E}_2)(\mathbf{I}_2)^* \quad \text{and} \quad \mathbf{I}_1/\mathbf{I}_2 = 1/a = N_2/N_1$$

### 1.3 The Non-ideal Transformer and its Equivalent Circuit

Figure 2 depicts an idealised transformer in which windings of zero resistance link the same flux which is carried within a lossless magnetic core having zero reluctance. The concept of reluctance was discussed in sections 4 and 5 of Unit FB-DC6. Remember that magnetic circuits behave in an analogous way to electric circuits. An ‘MMF’ represented by ‘Amper-turns’ drives a ‘Flux’ through a magnetic circuit the ‘resistance’ of which is known as ‘Reluctance’.

It is common practice in electrical engineering to represent the circuit behaviour of a complex physical device such as a transistor or an alternator in terms of an ‘equivalent circuit’. Such equivalent circuits can be made to simulate to a surprisingly good accuracy the operational characteristics of devices. The equivalent circuits are then located within an overall circuit diagram that links various components and the rules of circuit analysis are then applied to determine the behaviour of the system as a whole.

We are now ready to discuss the characteristics of a realistic transformer.

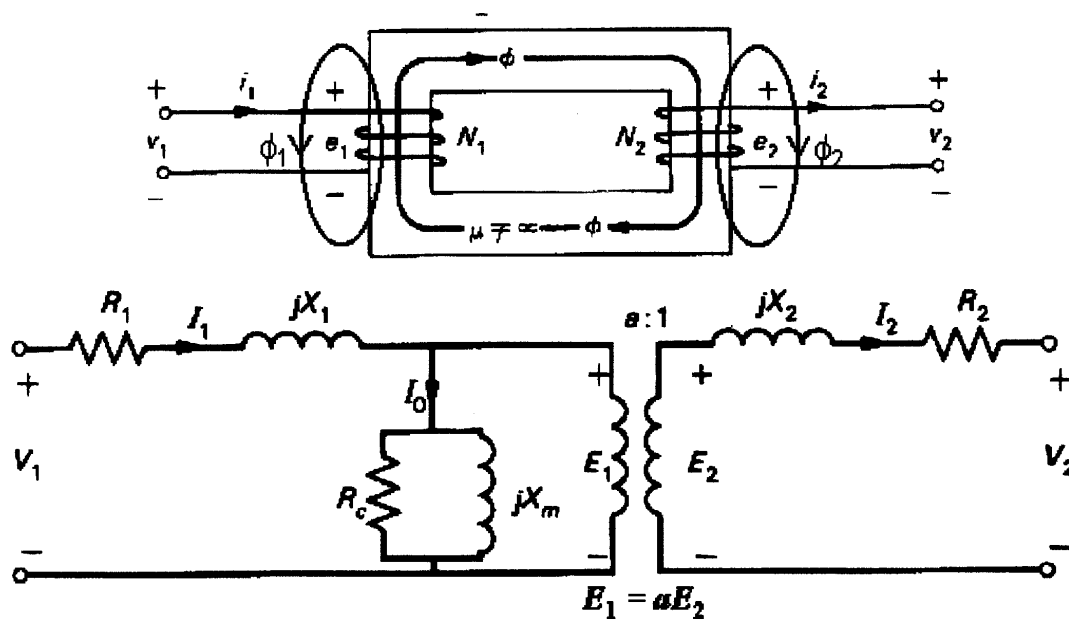

Fig. 3

The idealised transformer of Fig.1 is represented in fig. 2 by the two windings of turn ratio ‘a:1’ coupling emf’s  $E_1$  and  $E_2$  at the centre of the diagram. This idealised ‘equivalent circuit’ will be enhanced by the addition of other external components to represent the imperfections of the actual transformer:

- a) Transformer windings possess some resistance hence  $R_1$  and  $R_2$  are added in series with the primary and secondary windings to represent this imperfection.
- b) Unlike electrical circuits in which the current is virtually contained in the copper wiring because of the extremely high resistance of the surroundings, in magnetic circuits air is not a ‘magnetic insulator’. Hence, as shown in Fig.3 some flux ‘leaks’ out of the core and links separately windings 1 and 2. The variation of this flux produces emfs of self-inductance in the two windings and is represented in the equivalent circuit by the series reactances  $jX_1$  and  $jX_2$ .
- c) When the transformer is driven by a voltage on the primary but the secondary winding is not connected to a load and therefore carries no current, the primary current should also be zero. In fact, an ammeter in the primary circuit of a real transformer will record a current. This is due to the fact that the reluctance of the core is not infinite, i.e. the primary winding has a finite value of reactance. This ‘magnetising’ reactance is represented by the shunt element  $jX_m$  in the equivalent circuit. Additionally, we know that the alternating magnetisation of ferromagnetic materials incurs hysteresis and eddy-current losses (Sections 4 and 5 Unit FB-DC6). The shunt resistor  $R_c$  in the equivalent circuit represents these losses. The combined current taken by  $R_c$  and  $X_m$  results in the transformer no-load current  $I_o$ .

The various components of the transformer equivalent circuit can be easily determined using standard tests.

## 1.4 Further Details on Transformers

### **Construction:**

- To minimise resistance losses, the windings consist of high conductivity copper. The cores are of high permeability steel selected for low hysteresis loss and laminated to minimise eddy-current loss. The sum of hysteresis and eddy-current power is called *core loss* or *iron loss* in contrast to *copper loss* due to the  $I^2R$  power in the windings.
- The heat generated within the transformer has to be extracted to limit the temperature rise. Power transformers are often immersed in oil, which acts both as a good insulator and as a heat exchange medium to an external heat exchanger. Airflow to this heat exchanger could be natural or fan forced.
- Transformers have no moving parts hence they have efficiencies in the upper nineties.

### **Tap-change transformer:**

- On large transformers, taps on the windings allow small adjustments on the turns ratio. Often these taps are operated by an automatic tap-changer that maintains the voltage, usually on the secondary, at a fixed value irrespective of the load on the transformer.

***Transformer rating:***

- The manufacturer of an electrical machine such as a transformer will indicate on the nameplate the normal operating conditions: a typical nameplate might read: “Transformer, 11,000:415 V, 50Hz, 500kVA”
- The rated output of 500kVA can be maintained continuously without excessive heating and the consequential deterioration of the winding insulation.
- Because the heating is dependent on the square of the current, the output is rated in apparent power (kVA) rather than active power (kW). Supplying a zero power factor load, a transformer can be operating at rated output while delivering zero active power.

## 2. The Synchronous Machine

[This material relates predominantly to module ELP032]

### 2.1 Basic Constructional Characteristics

The generation of 3-phase voltages was briefly touched in section 10 of Unit FE-4. Figure 4 shows in greater detail the basic constructional features of a Synchronous Machine (SM).

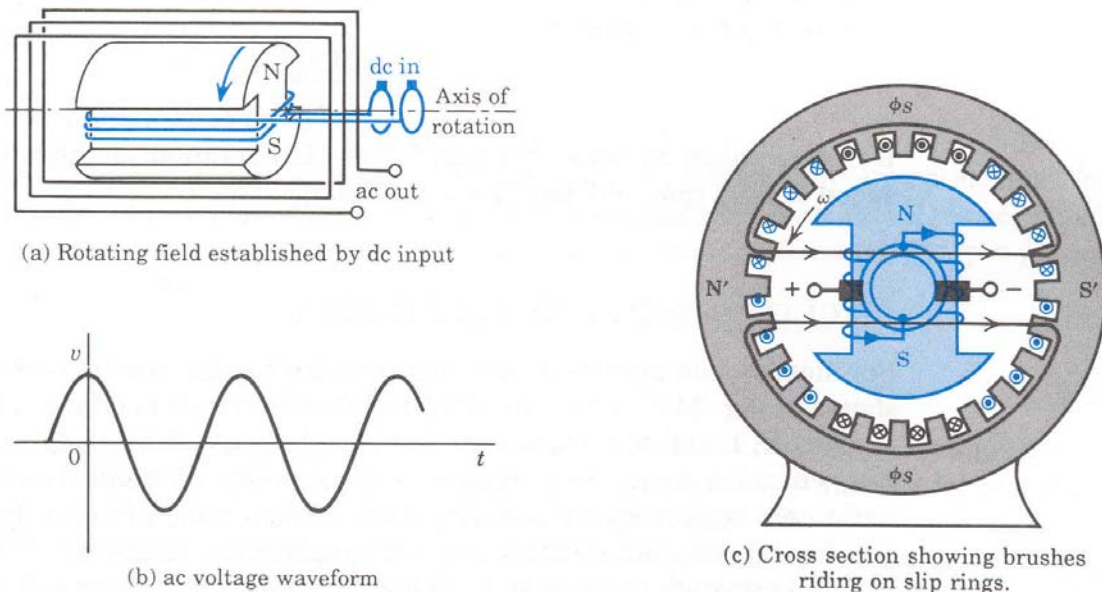

**Fig. 4**

To summarise:

- Field windings are mounted on the rotor, which forms a rotating electromagnet when fed from a DC source through slip rings.
- Three AC windings are mounted on the stator shifted by 120 degrees. These windings are connected to the three phase power network.

There are two basic rotor designs. These are illustrated in Fig. 5. The cylindrical rotor is suitable for low number of magnetic poles (usually two) and for high speed applications such as steam turbines. The salient rotor is chosen when a high number of poles is required for low speed applications such as hydro-turbines and wind-turbines. In the latter application over one hundred salient poles may be necessary.



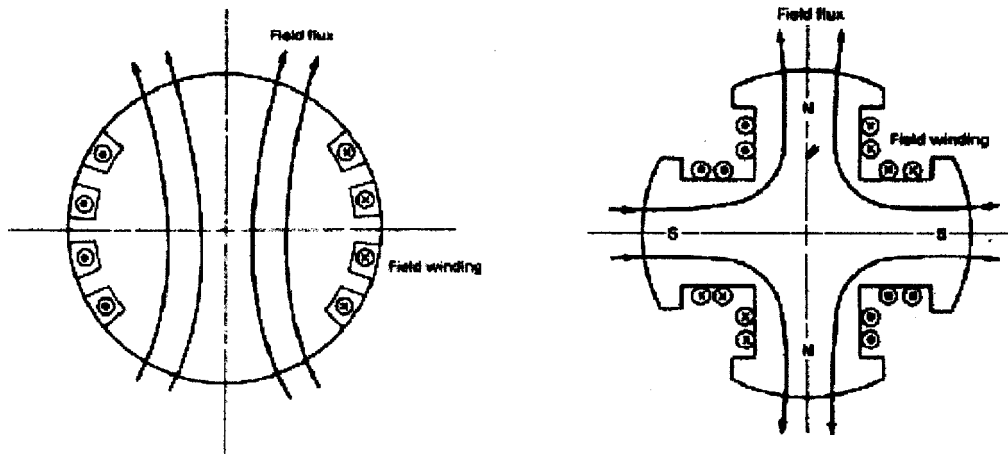

2-Pole Cylindrical Rotor

4-Pole Salient Rotor

**Fig. 5**

## 2.2 The Rotating Magnetic Field

When the three windings of Fig. 4(c) are connected to the mains, a most important phenomenon takes place which is fundamental to the operation of synchronous and induction generators and motors. This effect is explained in terms of the mmf contributions by the three balanced currents in Fig. 6(a). The instantaneous values of the currents are shown in (b). The three windings spread over one third of the periphery each in fig. 4(c) are shown as concentrated windings in Fig. 6(c). Positive currents in the concentrated windings in 6(c) produce mmfs in the directions indicated. In 6(d), successive instants at 0,30,60 and 90 degrees are shown and the contributions by the three winding mmfs and consequential fluxes are added vectorially. The resulting total stator flux has rotated by 90 degrees in space as we have progressed through 90 degrees in the evolution of the instantaneous currents of Fig. 6(b). This extraordinary fact, i.e. that a rotating magnetic field in space is produced by stationary coils carrying three-phase currents, was conceived by Nicolas Tessa in the late eighteen eighties.

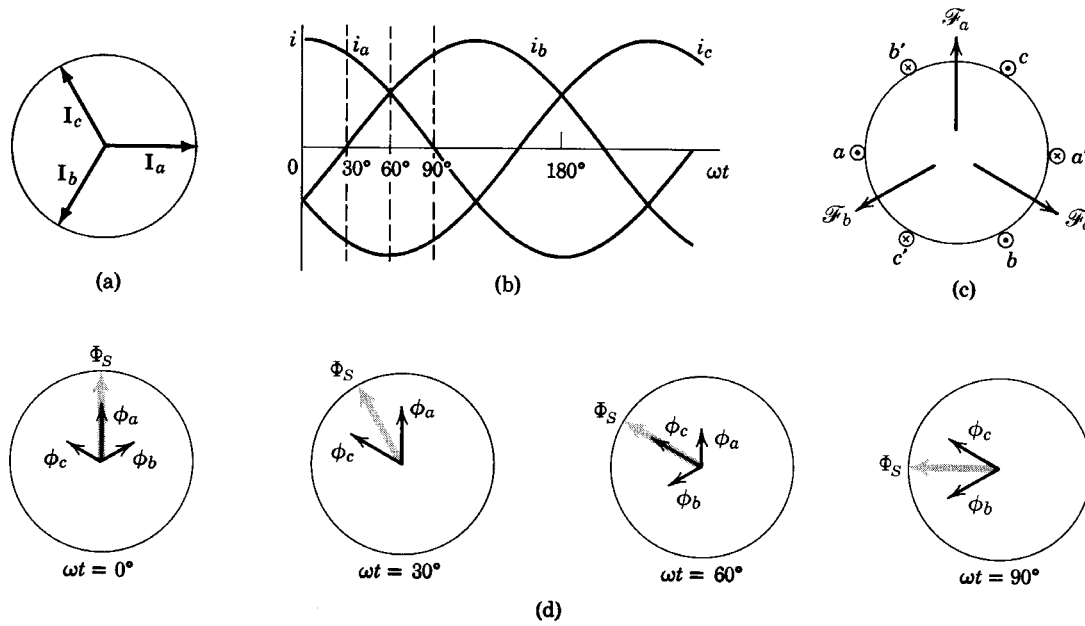

Fig 6

### 2.3 The Mode of Operation of the Synchronous Machine

We have now established that with the three stator windings of Fig.4 (c) connected to a three-phase supply, a rotating magnetic field is produced within the space of the hollow cylindrical stator. The field, according to Fig. 6, rotates through one revolution for each cycle of the AC supply i.e. for a 50Hz supply the field rotates 50 revolutions per second i.e. 3000 revolutions per minute. This is known as the synchronous speed  $N_s$ .

The stationary N-S magnet of the rotor of Fig.4(c) experiences the Rotating Magnetic Field (RMF) as a series of alternating impulses of attraction and repulsion at a rate of  $2 \times 50$  a second. It should be clear that due to its inertia the rotor remains stationary. If now, through some external means, the rotor is accelerated in the direction of rotation of the RMF until it reaches synchronous speed, at a time when the relative motion between the rotor and the RMF is close to zero, the two fields will lock in synchronism. This process is known as the ‘synchronisation’ of the machine.

In this state, and assuming that the machine is electrically and mechanically lossless, the rotor will rotate in sympathy with the RMF, the magnetic axis of the rotor field being aligned to the magnetic axis of the RMF. If an external torque is applied endeavouring to accelerate the rotor, the magnetic axis of the rotor will marginally advance with respect to the axis of the RMF, however the two locked fields will still rotate at the synchronous speed dictated by the supply frequency. The applied torque times the speed must represent

mechanical power fed into the machine. The conservation of energy principle demands that electrical power is fed out of the machine, which is now acting as a generator (alternator). Conversely, if a braking torque is applied to the shaft, the rotor magnetic axis is marginally retarded with respect to the axis of the RMF with the two fields still remaining in synchronism. Mechanical energy is now extracted from the shaft whilst electrical power is fed into the machine, which is now acting as a synchronous motor. The same machine functions as an alternator or motor, the only difference being the direction of energy flow.

If an excessive generating or motoring torque is applied then the magnetic forces linking the two fields together may not be sufficient to maintain the locking effect and synchronism will be lost. Operation under these conditions is highly undesirable and protection equipment will be brought into action to disconnect the synchronous machine from the mains. SM's are designed so that their rated conditions are far removed from the point of loss of synchronism thus operating stability is safely maintained under most normal conditions.

The speed at which SM's operate depends on the number of poles of the rotor. The four-pole salient rotor of Fig. 5 has only to run at half the speed of the two-pole cylindrical rotor of the same figure for a 50Hz voltage to be induced in a single-phase winding spanning 90 degrees on the stator.

Such a four pole SM will have a synchronous speed of 25 rps.

In general, the relationship between the mains frequency  $f$  (HZ), synchronous speed  $N_s$  (RPS) and number of pole pairs  $p$  is

$$N_s = f/p \quad (1)$$

For network analysis purposes the synchronous machine can be represented by an equivalent circuit that will be developed in module ELP032.

### 3. The induction machine

[This material relates predominantly to modules ELP032, ELP034, ELP041]

#### 3.1 Construction

Induction machines, in their motoring operating mode, are the most widely used electromechanical converters.

In an induction machine the stator is identical to the one for synchronous machines (Fig.4) in which 3-phase currents supplied to the stator produce a Rotating Magnetic Field (RMF). The stator however is radically different and does not have an external magnetising source. Instead, alternating currents are generated in the rotor from the stator through induction. It is the interaction between these induced rotor currents and the stator RMF that results in torque production.

In its most common form, the rotor consists of axial conductors shorted at the ends by circular rings to form a *squirrel cage* (Fig 7).

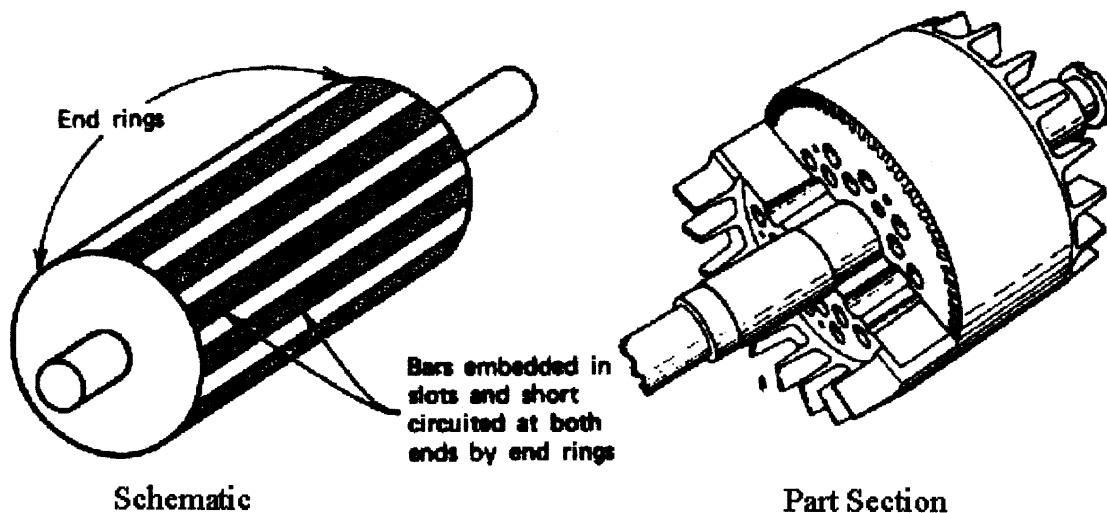

Fig. 7

A more versatile but more expensive and less rugged construction is the *wound-rotor* shown in Fig.8. The modules on Wind Power will explain why induction generators of squirrel cage or wound rotor design are extensively used in wind turbines.

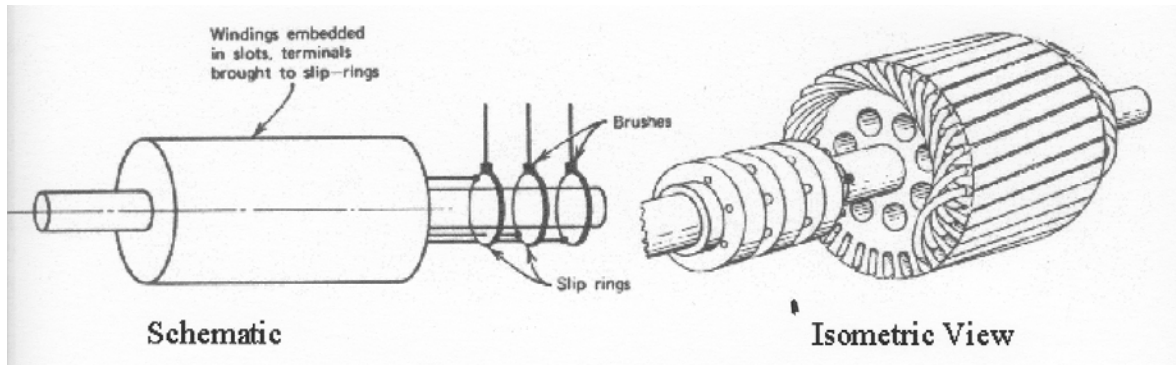

Fig 8

### 3.2 Mode of Operation

Although for the purposes of renewable energy sources we are interested in the generation mode, the initial description of the operation of the induction machine will be done for the motoring mode.

As the stator RMF moves past the rotor conductors, three-phase emfs are induced in the conductors by flux cutting action. The stator RMF rotates at synchronous speed  $N_s$  given by eqn (1). For emfs to be induced in the rotor conductors they should possess some relative speed with respect to the stator RMF. The rotor therefore turns at a lower speed  $N_r$ . If the rotor turned at  $N_s$ , there would be no change in flux linkage, no induced voltage, no current in the rotor conductors, no rotor MMF, no interaction between the rotor and stator fields and no torque.

For constant torque interaction to take place the rotor RMF must rotate in synchronism with the stator RMF as in the case of the synchronous machine. How is this accomplished if the rotor rotates at a lower speed than  $N_s$ ? The small difference between  $N_s$  and  $N_r$  is expressed as a ratio with respect to  $N_s$  and is known as **slip s**.

$$s = (N_s - N_r) / N_s \quad (2)$$

and 
$$N_r = (1 - s)N_s \quad (3)$$

The relative motion between the stator RMF and the rotor determines how frequently the stator RMF cuts the rotating rotor conductors, so the frequency of the rotor currents  $f_r$  is:

$$f_r = sf$$

The frequency of the rotor currents determines  $N_{rr}$ , the speed of the rotor RMF *with respect to* the rotor:

$$N_{rr} = f_r / p = (sf) / p = sN_s$$

The speed of the rotor RMF with respect to the stationary stator is the rotor speed plus the rotor RMF's speed with respect to the rotor:

$$N_r + N_{rr} = (1 - s)N_s + sN_s = N_s$$

We conclude that the rotor and stator RMF's rotate together at synchronous speed as required for a uniform torque to be developed as in the synchronous machine. However, in contrast to the synchronous machine, the rotor RMF is produced through *induction* from the stator therefore the rotor must operate at a speed lower than synchronous. The larger the applied braking torque the higher the slip, the larger the induced emf's and resulting rotor currents, and the stronger the interaction between the two RMF's to produce an electrical torque equal and opposite to the braking torque. The induction motor therefore exhibits a small decrease in speed with increments in braking torque.

**Exercise:**

A six pole 50Hz induction motor runs at 4% slip at a certain load. Calculate the synchronous speed, the rotor speed, the frequency of the rotor currents, and the speed of the rotor RMF with respect to the rotor and the speed of the rotor RMF with respect to the stator.

The synchronous speed from eqn 1 is:  $N_s = f/p = 50/3$  rps =  $50 \times 60/3 = 1000$  rpm

The rotor speed from eqn 2 is:  $(1-s)N_s = (1-0.04) \times 1000 = 960$  rpm

The frequency of the rotor currents are:  $f_r = sf = 0.04 \times 50 = 2$  Hz

The speed of the rotor RMF with respect to the rotor:

$$N_{rr} = f_r \times 60/p = 2 \times 60/3 = 40 \text{ rpm}$$

The speed of the rotor RMF with respect to the stator:

$$N_r + N_{rr} = 960 + 40 = 1000$$

(i.e. the rotor and stator RMF's rotate together)

Typical characteristics of a medium size induction motor are given in Fig. 9. Current, power factor efficiency and torque are plotted against slip. The value of slip is zero when  $N_r = N_s$  (i.e. the machine is just *floating* with no braking torque applied) and it is unity when  $N_s = 0$  (eqn.2). The operating range of the motor is restricted to the far right of the graph between slip of zero (at no load) and a slip of approximately 0.05 or 5% at full load when the efficiency reaches its peak of about 90%. Note that as for the synchronous machine, there is a 'pullout' torque beyond which the motor will stall. However this condition is far away from the normal operating regime.

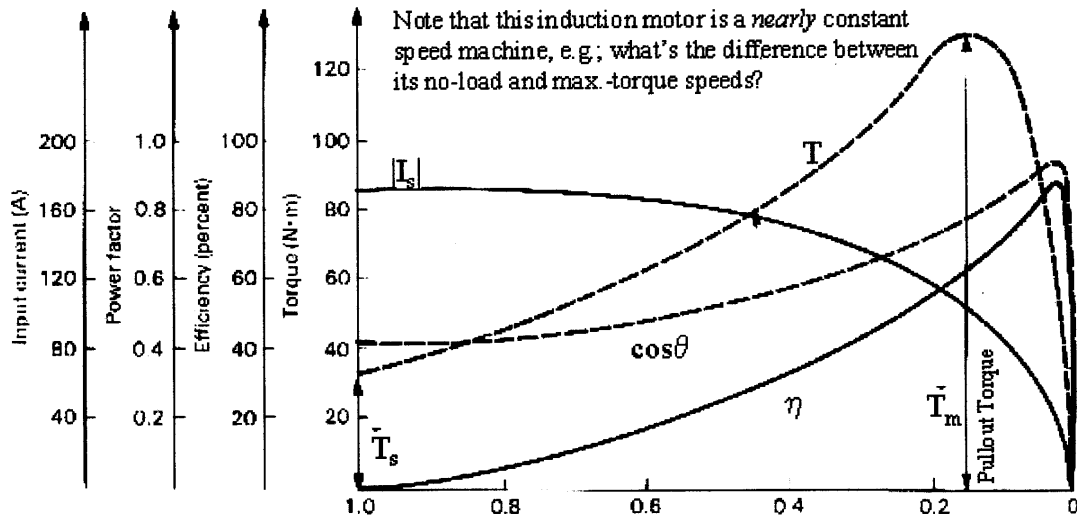

Fig 9

The induction machine will operate as an induction generator if from its ‘floating’ state at  $s=0$ , an accelerating rather than a decelerating torque is applied. Under these conditions, the speed of the rotor will exceed that of the stator RMF, the slip will be negative (eqn 2), power flow will be directed from the mechanical to the electrical side and the induction machine will act as a generator. The generator characteristics will be similar to those of the motor in Fig. 9 but with negative values of slip on the x-axis.

### 3.3 The Equivalent Circuit

The induction machine has certain similarities with the transformer. The stator can be viewed as the primary winding, which is connected to the mains. The rotor as the secondary winding in which a voltage is generated by induction from the primary. The differences are that the rotor induced voltage is a function of slip and that the power delivered by the secondary is mechanical rather than electrical in form.

Mathematical analysis of the induction machine can derive the equivalent circuit of Fig. 10. This has substantial similarities to the transformer equivalent circuit of Fig.3. As for the transformer, the components  $R_s$ ,  $X_s$ ,  $R_r$  and  $X_r$  represent the stator and rotor resistance and reactance respectively. The shunt component  $X_m$  represents the magnetising reactance of the stator. The major and most subtle difference is the nature of component  $(1-s)R_r / s$  which has no equivalence in the transformer. The power consumed in this element represents the electrical power converted into mechanical power in the motoring mode.

With the value of  $s$  negative, the power in this component represents the mechanical power converted into electrical power in the generating mode.

The equivalent circuit will be used in the Integration module to illustrate the use of induction generators in renewable energy systems.

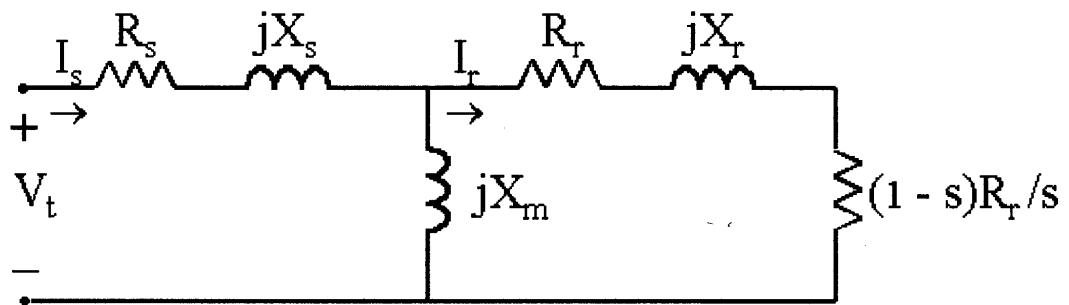

Fig 10