

FB-DC3 Electric Circuits: Series and Parallel Circuits

Contents

- 1. What are "series" and "parallel"?**
- 2. Simple series circuits**
- 3. Simple parallel circuits**
- 4. Conductance**

1. What are "series" and "parallel"?

Circuits consisting of just one battery and one load resistance are very simple to analyse, but they are not often found in practical applications. Usually, we find circuits where more than two components are connected together.

There are two basic ways in which to connect more than two circuit components: *series* and *parallel*. First, an example of a series circuit:

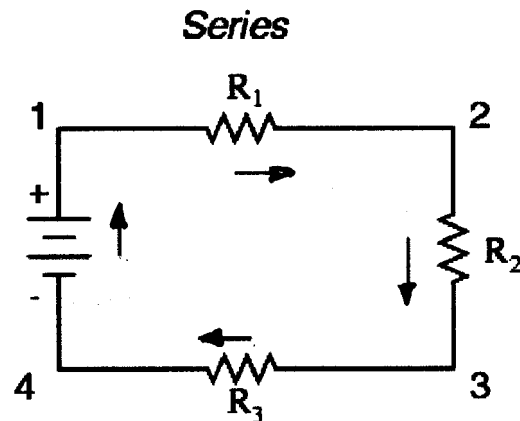

Here, we have three resistors (labelled R_1 , R_2 , and R_3), connected in a long chain from one terminal of the battery to the other. (It should be noted that the subscript labelling -- those little numbers to the lower-right of the letter "R" -- are unrelated to the resistor values in ohms. They serve only to identify one resistor from another.) The defining characteristic of a series circuit is that there is only one path for current to flow, in this case in a clockwise direction.

Now, let's look at the other type of circuit, a parallel configuration:

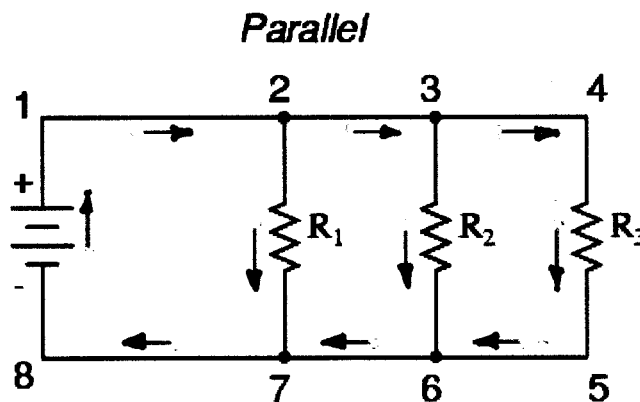

Again, we have three resistors, but this time they form more than one continuous path for current to flow. Each individual path (through R_1 , R_2 , and R_3) is called a *branch*.

The defining characteristic of a parallel circuit is that all components are connected between the same set of electrically common points. Looking at the schematic diagram, we see that points 1, 2, 3, and 4 are all electrically common. So are points 8, 7, 6, and 5. Note that all resistors as well as the battery are connected between these two sets of points.

And, of course, the complexity doesn't stop at simple series and parallel either! We can have circuits that are a combination of series and parallel, too:

Section Review:

- In a series circuit, all components are connected end-to-end, forming a single path for electrons to flow.
- In a parallel circuit, all components are connected across each other, forming exactly two sets of electrically common points.
- A "branch" in a parallel circuit is a path for electric current formed by one of the load components (such as a resistor).

2. Simple series circuits

Let's start with a series circuit consisting of three resistors and a single battery:

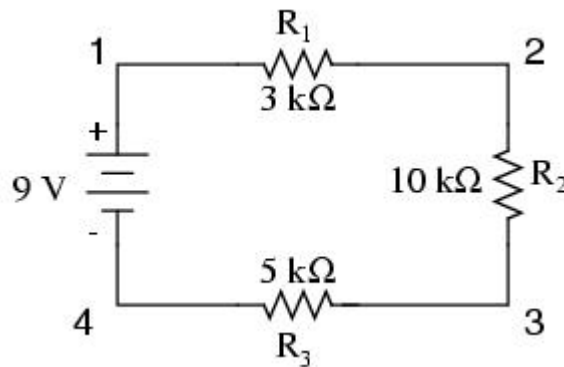

The first principle to understand about series circuits is that the amount of current is the same through any component in the circuit. This is because there is only one path for electrons to flow in a series circuit, and because free electrons flow through conductors like marbles in a tube, the rate of flow (marble speed) at any point in the circuit (tube) at any specific point in time must be equal.

From the way that the 9 volt battery is arranged, we can tell that the current in this circuit will flow in a clockwise direction, from point 1 to 2, 2 to 3, 3 to 4 and 4 to 1. However, we have one source of voltage and three resistances. How do we use Ohm's Law here?

An important caveat to Ohm's Law is that all quantities (voltage, current, resistance, and power) must relate to each other in terms of the same two points in a circuit. For instance, with a single-battery, single-resistor circuit, we could easily calculate any quantity because they all applied to the same two points in the circuit:

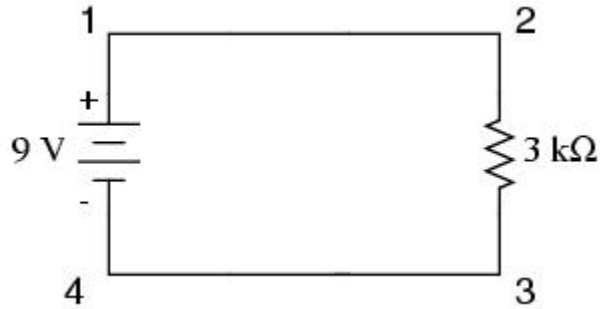

$$I = \frac{E}{R}$$

$$I = \frac{9 \text{ volts}}{3 \text{ k}\Omega} = 3 \text{ mA}$$

Since points 1 and 2 are connected together with wire of negligible resistance, as are points 3 and 4, we can say that point 1 is electrically common to point 2, and that point 3 is electrically common to point 4. Since we know we have 9 volts of electromotive force between points 1 and 4 (directly across the battery), and since point 2 is common to point 1 and point 3 common to point 4, we must also have 9 volts between points 2 and 3 (directly across the resistor). Therefore, we can apply Ohm's Law ($I = E/R$) to the current through the resistor, because we know the voltage (E) across the resistor and the resistance (R) of that resistor. All terms (E , I , R) apply to the same two points in the circuit, to that same resistor, so we can use the Ohm's Law formula with no reservation. However, in circuits containing more than one resistor, we must be careful in how we apply Ohm's Law. In the three-resistor example circuit below, we know that we have 9 volts between points 1 and 4, which is the amount of electromotive force trying to push electrons through the series combination of R_1 , R_2 , and R_3 . However, we cannot take the value of 9 volts and divide it by 3k, 10k or 5k Ω to try to find a current value, because we don't know how much voltage is across any one of those resistors, individually.

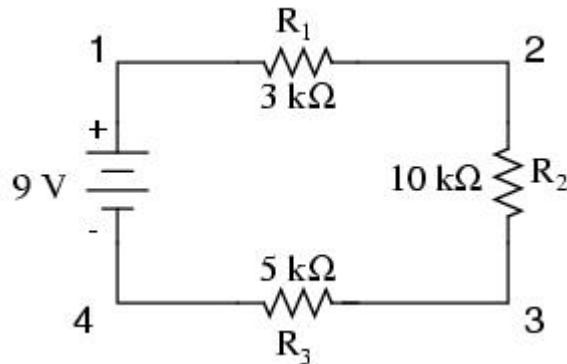

The figure of 9 volts is a *total* quantity for the whole circuit, whereas the figures of 3k, 10k, and 5k Ω are *individual* quantities for individual resistors. If we were to plug a

figure for total voltage into an Ohm's Law equation with a figure for individual resistance, the result would not relate accurately to any quantity in the real circuit. For R_1 , Ohm's Law will relate the amount of voltage across R_1 with the current through R_1 , given R_1 's resistance, $3\text{k}\Omega$:

$$I_{R1} = \frac{E_{R1}}{3 \text{ k}\Omega} \quad E_{R1} = I_{R1} (3 \text{ k}\Omega)$$

But, since we don't know the voltage across R_1 (only the total voltage supplied by the battery across the three-resistor series combination) and we don't know the current through R_1 , we can't do any calculations with either formula. The same goes for R_2 and R_3 : we can apply the Ohm's Law equations if and only if all terms are representative of their respective quantities between the same two points in the circuit.

So what can we do? We know the voltage of the source (9 volts) applied across the series combination of R_1 , R_2 , and R_3 , and we know the resistances of each resistor, but since those quantities aren't in the same context, we can't use Ohm's Law to determine the circuit current. If only we knew what the *total* resistance was for the circuit: then we could calculate *total* current with our figure for *total* voltage ($I=E/R$).

This brings us to the second principle of series circuits: the total resistance of any series circuit is equal to the sum of the individual resistances. This should make intuitive sense: the more resistors in series that the electrons must flow through, the more difficult it will be for those electrons to flow. In the example problem, we had a $3 \text{ k}\Omega$, $10 \text{ k}\Omega$, and $5\text{k}\Omega$ resistor in series, giving us a total resistance of $18 \text{ k}\Omega$:

$$R_{\text{total}} = R_1 + R_2 + R_3$$

$$R_{\text{total}} = 3 \text{ k}\Omega + 10 \text{ k}\Omega + 5 \text{ k}\Omega$$

$$R_{\text{total}} = 18 \text{ k}\Omega$$

In essence, we've calculated the equivalent resistance of R_1 , R_2 , and R_3 combined. Knowing this, we could re-draw the circuit with a single equivalent resistor representing the series combination of R_1 , R_2 , and R_3 :

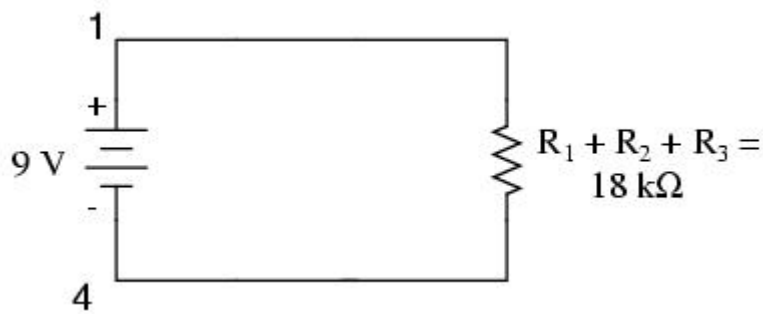

Now we have all the necessary information to calculate circuit current, because we have the voltage between points 1 and 4 (9 volts) and the resistance between points 1 and 4 (18 k Ω):

$$I_{\text{total}} = \frac{E_{\text{total}}}{R_{\text{total}}}$$

$$I_{\text{total}} = \frac{9 \text{ volts}}{18 \text{ k}\Omega} = 500 \mu\text{A}$$

Knowing that current is equal through all components of a series circuit (and we just determined the current through the battery), we can go back to our original circuit schematic and note the current through each component:

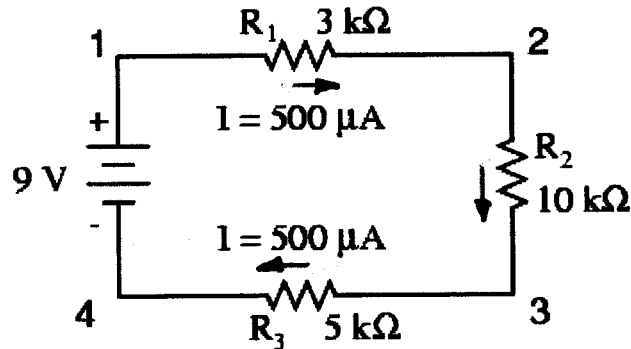

Now that we know the amount of current through each resistor, we can use Ohm's Law to determine the voltage drop across each one (applying Ohm's Law in its proper context):

$$E_{R1} = I_{R1} R_1$$

$$E_{R2} = I_{R2} R_2$$

$$E_{R3} = I_{R3} R_3$$

$$E_{R1} = (500 \mu\text{A})(3 \text{ k}\Omega) = 1.5 \text{ V}$$

$$E_{R2} = (500 \mu\text{A})(10 \text{ k}\Omega) = 5 \text{ V}$$

$$E_{R3} = (500 \mu\text{A})(5 \text{ k}\Omega) = 2.5 \text{ V}$$

Notice the voltage drops across each resistor, and how the sum of the voltage drops (1.5 + 5 + 2.5) is equal to the battery (supply) voltage: 9 volts. This is the third principle of series circuits: that the supply voltage is equal to the sum of the individual voltage drops.

Section Review:

- Components in a series circuit share the same current:

$$I_{\text{Total}} = I_1 = I_2 = \dots I_n$$
- Total resistance in a series circuit is equal to the sum of the individual resistances:

$$R_{\text{Total}} = R_1 + R_2 + \dots R_n$$
- Total voltage in a series circuit is equal to the sum of the individual voltage drops:

$$E_{\text{Total}} = E_1 + E_2 + \dots E_n$$

3. Simple parallel circuits

Let's start with a parallel circuit consisting of three resistors and a single battery:

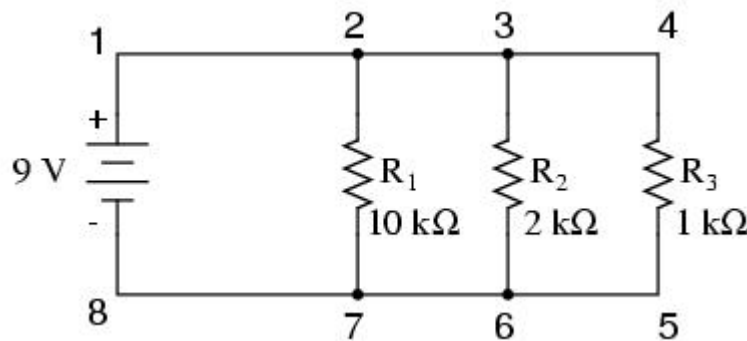

The first principle to understand about parallel circuits is that the voltage is equal across all components in the circuit. This is because there are only two sets of electrically common points in a parallel circuit, and voltage measured between sets of common points must always be the same at any given time. Therefore, in the above circuit, the voltage across R₁ is equal to the voltage across R₂ which is equal to the voltage across R₃ which is equal to the voltage across the battery.

Here we can immediately apply Ohm's Law to each resistor to find its current because we know the voltage across each resistor (9 volts) and the resistance of each resistor:

$$I_{R1} = \frac{E_{R1}}{R_1} \quad I_{R2} = \frac{E_{R2}}{R_2} \quad I_{R3} = \frac{E_{R3}}{R_3}$$

$$I_{R1} = \frac{9 \text{ V}}{10 \text{ k}\Omega} = 0.9 \text{ mA}$$

$$I_{R2} = \frac{9 \text{ V}}{2 \text{ k}\Omega} = 4.5 \text{ mA}$$

$$I_{R3} = \frac{9 \text{ V}}{1 \text{ k}\Omega} = 9 \text{ mA}$$

As there is no accumulation of charge at any part of the circuit we can conclude that the total circuit current is equal to the sum of the individual branch currents.

i.e. **$I_t = 0.9 + 4.5 + 9 = 14.4 \text{ mA}$**

Finally, applying Ohm's Law we can calculate the total circuit resistance:

$R_t = E_t / I_t = 9 / 14.4 = 625 \text{ ohm}$

Please note something very important here. The total circuit resistance is only 625Ω : *less* than any one of the individual resistors. In the series circuit, where the total resistance was the sum of the individual resistances, the total was bound to be *greater* than any one of the resistors individually. Here in the parallel circuit, however, the opposite is true: we say that the individual resistances *diminish* rather than *add* to make the total. Mathematically, the relationship between total resistance and individual resistances in a parallel circuit looks like this:

$$R_{\text{total}} = \frac{1}{\frac{1}{R_1} + \frac{1}{R_2} + \frac{1}{R_3}}$$

The same basic form of equation works for *any* number of resistors connected together in parallel, just add as many $1/R$ terms on the denominator of the fraction as needed to accommodate all parallel resistors in the circuit.

In summary, a parallel circuit is defined as one where all components are connected between the same set of electrically common points. Another way of saying this is that all components are connected across each other's terminals. From this definition, three rules of parallel circuits follow: all components share the same voltage; resistances diminish to equal a smaller, total resistance; and branch currents add to equal a larger, total current. Just as in the case of series circuits, all of these rules find root in the definition of a parallel circuit. If you understand that definition fully, then the rules are nothing more than footnotes to the definition.

Section Review:

- Components in a parallel circuit share the same voltage:

$$E_{\text{Total}} = E_1 = E_2 = \dots E_n$$
- Total resistance in a parallel circuit is *less* than any of the individual resistances:

$$R_{\text{Total}} = 1 / (1/R_1 + 1/R_2 + \dots 1/R_n)$$
- Total current in a parallel circuit is equal to the sum of the individual branch currents:

$$I_{\text{Total}} = I_1 + I_2 + \dots I_n.$$

4. Conductance

When students first see the parallel resistance equation, the natural question to ask is, "Where did *that* thing come from?" It is truly an odd piece of arithmetic, and its origin deserves a good explanation.

Resistance, by definition, is the measure of *friction* a component presents to the flow of electrons through it. Resistance is symbolised by the capital letter "R" and is measured in the unit of "ohm." However, we can also think of this electrical property in terms of its inverse: how *easy* it is for electrons to flow through a component, rather than how *difficult*. If *resistance* is the word we use to symbolise the measure of how difficult it is for electrons to flow, then a good word to express how easy it is for electrons to flow would be *conductance*.

Mathematically, conductance is the reciprocal, or inverse, of resistance:

$$\text{Conductance} = \frac{1}{\text{Resistance}}$$

The greater the resistance, the less the conductance, and visa-versa. This should make intuitive sense, resistance and conductance being opposite ways to denote the same essential electrical property. If two components' resistances are compared and it is found that component "A" has one-half the resistance of component "B," then we could alternatively express this relationship by saying that component "A" is *twice* as conductive as component "B." If component "A" has but one-third the resistance of component "B," then we could say it is *three times* more conductive than component "B," and so on.

Carrying this idea further, a symbol and unit were created to represent conductance. The symbol is the capital letter "G" and the unit is the *mho*, which is "ohm" spelled backwards (and you didn't think electronics engineers had any sense of humour!). Despite its appropriateness, the unit of the mho was replaced in later years by the unit of *siemens* (abbreviated by the capital letter "S").

Back to our parallel circuit example, we should be able to see that multiple paths (branches) for current reduces total resistance for the whole circuit, as electrons are able to flow easier through the whole network of multiple branches than through any one of those branch resistances alone. In terms of *resistance*, additional branches result in a lesser total (current meets with less opposition). In terms of *conductance*, however, additional branches results in a greater total (electrons flow with greater conductance): Total parallel resistance is *less* than any one of the individual branch resistances because parallel resistors resist less together than they would separately:

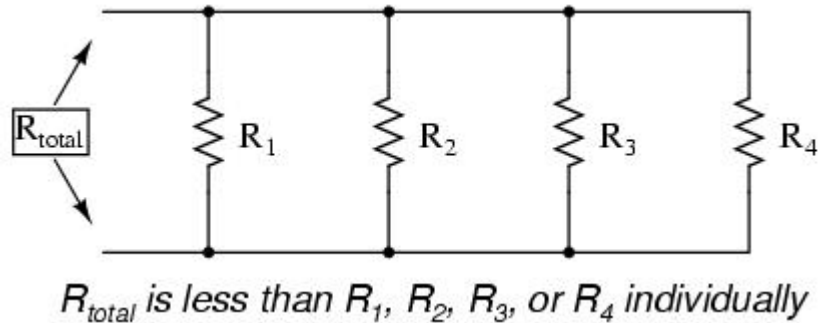

Total parallel conductance is *greater* than any of the individual branch conductances because parallel resistors conduct better together than they would separately:

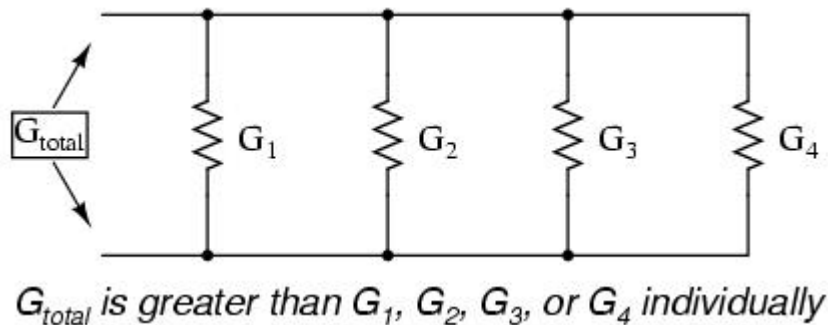

To be more precise, the total conductance in a parallel circuit is equal to the sum of the individual conductances:

$$G_{total} = G_1 + G_2 + G_3 + G_4$$

If we know that conductance is nothing more than the mathematical reciprocal ($1/x$) of resistance, we can translate each term of the above formula into resistance by substituting the reciprocal of each respective conductance:

$$\frac{1}{R_{\text{total}}} = \frac{1}{R_1} + \frac{1}{R_2} + \frac{1}{R_3} + \frac{1}{R_4}$$

Solving the above equation for total resistance (instead of the reciprocal of total resistance), we can invert (reciprocate) both sides of the equation:

$$R_{\text{total}} = \frac{1}{\frac{1}{R_1} + \frac{1}{R_2} + \frac{1}{R_3} + \frac{1}{R_4}}$$

So, we arrive at our cryptic resistance formula at last! Conductance (G) is seldom used as a practical measurement, and so the above formula is a common one to see in the analysis of parallel circuits.

Section Review:

- Conductance is the opposite of resistance: the measure of how *easy* is it for electrons to flow through something.
- Conductance is symbolised with the letter "G" and is measured in units of *mhos* or *Siemens*.
- Mathematically, conductance equals the reciprocal of resistance: $G = 1/R$