

FB-DC8 Electric Circuits: RC and L/R Time Constants

Contents

- 1. Capacitor transient response**
- 2. Inductor transient response**
- 3. Voltage and current calculations**
- 4. Why L/R and not LR?**
- 5. Complex voltage and current calculations**

Electrical transients

This chapter explores the response of capacitors and inductors sudden changes in DC voltage (called a *transient* voltage), when wired in series with a resistor. Unlike resistors, which respond instantaneously to applied voltage, capacitors and inductors react over time as they absorb and release energy.

1. Capacitor transient response

Because capacitors store energy in the form of an electric field, they tend to act like small secondary-cell batteries, being able to store and release electrical energy. A fully discharged capacitor maintains zero volts across its terminals, and a charged capacitor maintains a steady quantity of voltage across its terminals, just like a battery. When capacitors are placed in a circuit with other sources of voltage, they will absorb energy from those sources, just as a secondary-cell battery will become charged as a result of being connected to a generator. A fully discharged capacitor, having a terminal voltage of zero, will initially act as a short-circuit when attached to a source of voltage, drawing maximum current as it begins to build a charge. Over time, the capacitor's terminal voltage rises to meet the applied voltage from the source, and the current through the capacitor decreases correspondingly. Once the capacitor has reached the full voltage of the source, it will stop drawing current from it, and behave essentially as an open-circuit.

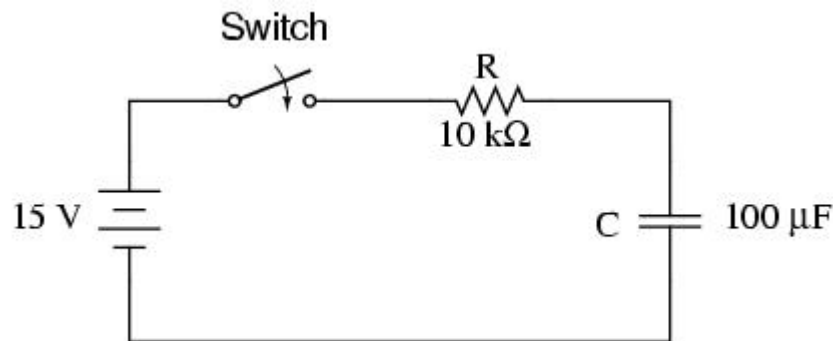

When the switch is first closed, the voltage across the capacitor (which we were told was fully discharged) is zero volts; thus, it first behaves as though it were a short-circuit. Over time, the capacitor voltage will rise to equal battery voltage, ending in a condition where the capacitor behaves as an open-circuit. Current through the circuit is determined by the difference in voltage between the battery and the capacitor, divided by the resistance of 10kΩ. As the capacitor voltage approaches the battery voltage, the current approaches zero. Once the capacitor voltage has reached 15 volts, the current will be exactly zero. Let's see how this works using real values:

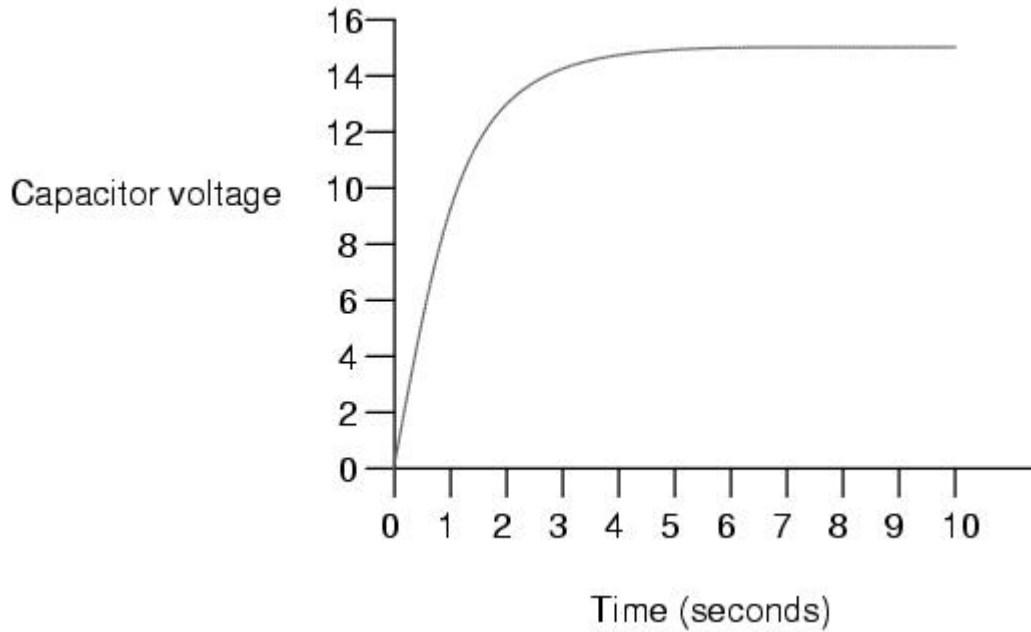

The capacitor voltage's approach to 15 volts and the current's approach to zero over time is what a mathematician would call *asymptotic*: that is, they both approach their final values, getting closer and closer over time, but never exactly reaches their destinations. For all practical purposes, though, we can say that the capacitor voltage will eventually reach 15 volts and that the current will eventually equal zero.

Section Review:

- Capacitors act somewhat like secondary-cell batteries when faced with a sudden change in applied voltage: they initially react by producing a high current which tapers off over time.
- A fully discharged capacitor initially acts as a short circuit (current with no voltage drop) when faced with the sudden application of voltage. After charging fully to that level of voltage, it acts as an open circuit (voltage drop with no current).
- In a resistor-capacitor charging circuit, capacitor voltage goes from nothing to full source voltage while current goes from maximum to zero, both variables changing most rapidly at first, approaching their final values slower and slower as time goes on.

2. Inductor transient response

Inductors have the exact opposite characteristics of capacitors. Whereas capacitors store energy in an *electric* field (produced by the voltage between two plates), inductors store energy in a *magnetic* field (produced by the current through wire). Thus, while the stored energy in a capacitor tries to maintain a constant voltage across its terminals, the stored energy in an inductor tries to maintain a constant current through its windings. Because of this, inductors oppose changes in current, and act precisely the opposite of capacitors, which oppose changes in voltage. A fully discharged inductor (no magnetic field), having zero current through it, will initially act as an open-circuit when attached to a source of voltage (as it tries to maintain zero current), dropping maximum voltage across its leads. Over time, the inductor's current rises to the maximum value allowed by the circuit, and the terminal voltage decreases correspondingly. Once the inductor's terminal voltage has decreased to a minimum (zero for a "perfect" inductor), the current will stay at a maximum level, and it will behave essentially as a short-circuit.

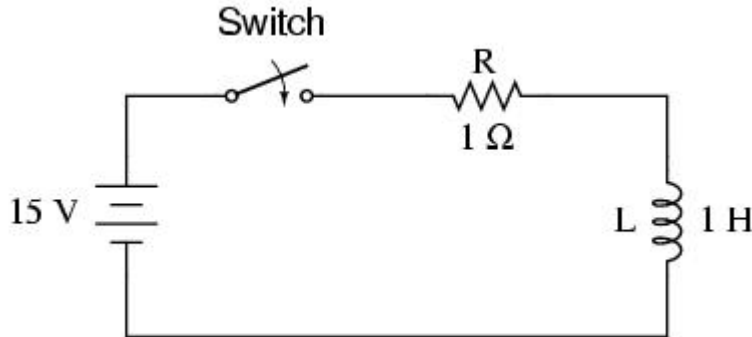

When the switch is first closed, the voltage across the inductor will immediately jump to battery voltage (acting as though it were an open-circuit) and decay down to zero over time (eventually acting as though it were a short-circuit). Voltage across the inductor is determined by calculating how much voltage is being dropped across R, given the current through the inductor, and subtracting that voltage value from the battery to see what's left. When the switch is first closed, the current is zero, then it increases over time until it is equal to the battery voltage divided by the series resistance of $1\ \Omega$. This behaviour is precisely opposite that of the series resistor-capacitor circuit, where current started at a maximum and capacitor voltage at zero. Let's see how this works using real values:

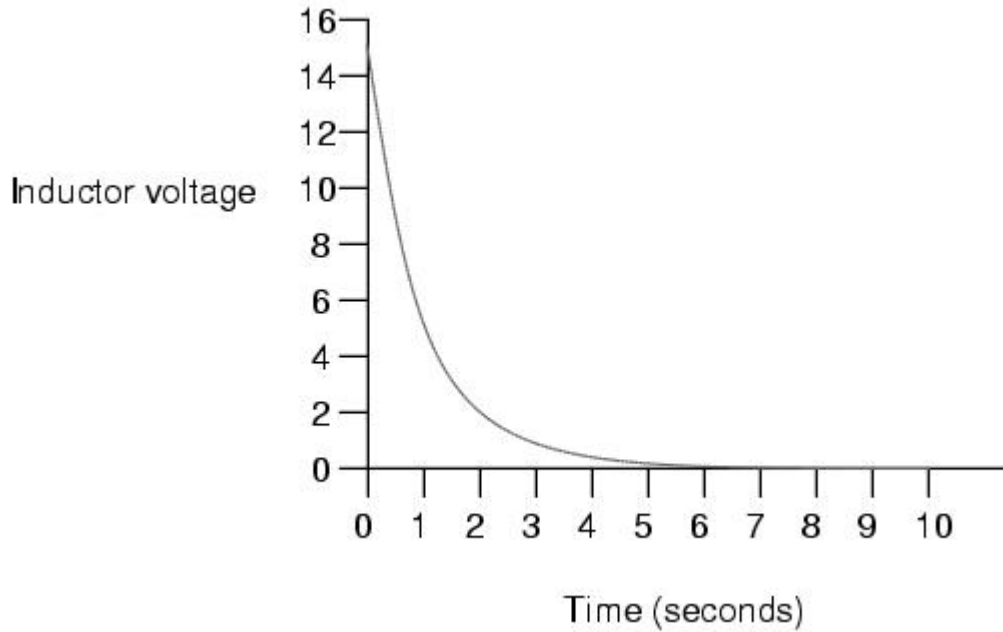

Section Review:

- A fully "discharged" inductor (no current through it) initially acts as an open circuit (voltage drop with no current) when faced with the sudden application of voltage. After "charging" fully to the final level of current, it acts as a short circuit (current with no voltage drop).
- In a resistor-inductor "charging" circuit, inductor current goes from nothing to full value while voltage goes from maximum to zero, both variables changing most rapidly at first, approaching their final values slower and slower as time goes on.

3. Voltage and current calculations

There's a sure way to calculate any of the values in a reactive DC circuit over time. The first step is to identify the starting and final values for whatever quantity the capacitor or inductor opposes change in; that is, whatever quantity the reactive component is trying to hold constant. For capacitors, this quantity is *voltage*; for inductors, this quantity is *current*. When the switch in a circuit is closed (or opened), the reactive component will attempt to maintain that quantity at the same level as it was before the switch transition, so that value is to be used for the "starting" value. The final value for this quantity is whatever that quantity will be after an infinite amount of time. This can be determined by analysing a capacitive circuit as though the capacitor was an open-circuit, and an inductive circuit as though the inductor was a short-circuit, because that is what these components behave as when they've reached "full charge," after an infinite amount of time.

The next step is to calculate the *time constant* of the circuit: the amount of time it takes for voltage or current values to change approximately 63 percent from their starting values to their final values in a transient situation. In a series RC circuit, the time constant is equal to the total resistance in ohms multiplied by the total capacitance in farads. For a

series LR circuit, it is the total inductance in henrys divided by the total resistance in ohms. In either case, the time constant is expressed in units of *seconds* and symbolized by the Greek letter "tau" (τ):

For resistor-capacitor circuits:

$$\tau = RC$$

For resistor-inductor circuits:

$$\tau = \frac{L}{R}$$

The rise and fall of circuit values such as voltage or current in response to a transient is, as was mentioned before, asymptotic. Being so, the values begin to rapidly change soon after the transient and settle down over time. If plotted on a graph, the approach to the final values of voltage and current form exponential curves.

As was stated before, one time constant is the amount of time it takes for any of these values to change about 63 percent from their starting values to their (ultimate) final values. For every time constant, these values move (approximately) 63 percent closer to their eventual goal. The mathematical formula for determining the precise percentage is quite simple:

$$\text{Percentage of change} = \left(1 - \frac{1}{e^{t/\tau}}\right) \times 100\%$$

The letter e stands for Euler's constant, which is approximately 2.7182818. It is derived from calculus techniques, after mathematically analysing the asymptotic approach of the circuit values. After one time constant's worth of time, the percentage of change from starting value to final value is:

$$\left(1 - \frac{1}{e^1}\right) \times 100\% = 63.212\%$$

After two time constant's worth of time, the percentage of change from starting value to final value is:

$$\left(1 - \frac{1}{e^2}\right) \times 100\% = 86.466\%$$

After ten time constant's worth of time, the percentage is:

$$\left(1 - \frac{1}{e^{10}}\right) \times 100\% = 99.995\%$$

The more time that passes since the transient application of voltage from the battery, the larger the value of the denominator in the fraction, which makes for a smaller value for

the whole fraction, which makes for a grand total (1 minus the fraction) approaching 1, or 100 percent.

We can make a more universal formula out of this one for the determination of voltage and current values in transient circuits, by multiplying this quantity by the difference between the final and starting circuit values:

Universal Time Constant Formula

$$\text{Change} = (\text{Final}-\text{Start}) \left(1 - \frac{1}{e^{t/\tau}} \right)$$

Where,

Final = Value of calculated variable after infinite time
(its *ultimate* value)

Start = Initial value of calculated variable

e = Euler's number (≈ 2.7182818)

t = Time in seconds

τ = Time constant for circuit in seconds

Let's analyse the voltage rise on the series resistor-capacitor circuit shown at the beginning of the chapter.

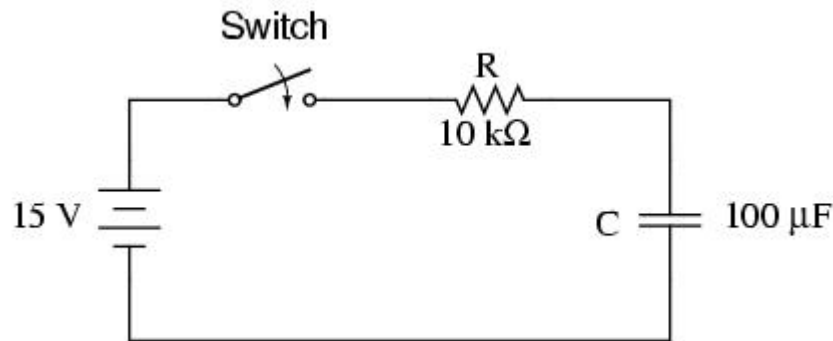

Note that we're choosing to analyse voltage because that is the quantity capacitors tend to hold constant. Although the formula works quite well for current, the starting and final values for current are actually derived from the capacitor's voltage, so calculating voltage is a more direct method. The resistance is 10kΩ, and the capacitance is 100 μF (microfarads). Since the time constant (τ) for an RC circuit is the product of resistance and capacitance, we obtain a value of 1 second:

$$\tau = RC$$

$$\tau = (10 \text{ k}\Omega)(100 \text{ }\mu\text{F})$$

$$\tau = 1 \text{ second}$$

If the capacitor starts in a totally discharged state (0 volts), then we can use that value of voltage for a "starting" value. The final value, of course, will be the battery voltage (15 volts). Our universal formula for capacitor voltage in this circuit looks like this:

$$\text{Change} = (\text{Final-Start}) \left(1 - \frac{1}{e^{t/\tau}} \right)$$

$$\text{Change} = (15 \text{ V} - 0 \text{ V}) \left(1 - \frac{1}{e^{t/1}} \right)$$

So, after 7.25 seconds of applying voltage through the closed switch, our capacitor voltage will have increased by:

$$\text{Change} = (15 \text{ V} - 0 \text{ V}) \left(1 - \frac{1}{e^{7.25/1}} \right)$$

$$\text{Change} = (15 \text{ V} - 0 \text{ V})(0.99929)$$

$$\text{Change} = 14.989 \text{ V}$$

Since we started at a capacitor voltage of 0 volts, this increase of 14.989 volts means that we have 14.989 volts after 7.25 seconds.

The same formula will work for determining current in that circuit, too. Since we know that a discharged capacitor initially acts like a short-circuit, the starting current will be the maximum amount possible: 15 volts (from the battery) divided by 10k Ω (the only opposition to current in the circuit at the beginning):

$$\text{Starting current} = \frac{15 \text{ V}}{10 \text{ k}\Omega}$$

$$\text{Starting current} = 1.5 \text{ mA}$$

We also know that the final current will be zero, since the capacitor will eventually behave as an open-circuit, meaning that eventually no electrons will flow in the circuit. Now that we know both the starting and final current values, we can use our universal formula to determine the current after 7.25 seconds of switch closure in the same RC circuit:

$$\text{Change} = (0 \text{ mA} - 1.5 \text{ mA}) \left(1 - \frac{1}{e^{7.25/1}}\right)$$

$$\text{Change} = (0 \text{ mA} - 1.5 \text{ mA})(0.99929)$$

$$\text{Change} = - 1.4989 \text{ mA}$$

Note that the figure obtained for change is negative, not positive! This tells us that current has *decreased* rather than increased with the passage of time. Since we started at a current of 1.5mA, this decrease (-1.4989mA) means that we have 0.001065mA (1.065 μ A) after 7.25 seconds.

We could have also determined the circuit current at time=7.25 seconds by subtracting the capacitor's voltage (14.989 volts) from the battery's voltage (15 volts) to obtain the voltage drop across the 10k Ω resistor, then figuring current through the resistor (and the whole series circuit) with Ohm's Law ($I=E/R$). Either way, we should obtain the same answer:

$$I = \frac{E}{R}$$

$$I = \frac{15 \text{ V} - 14.989 \text{ V}}{10 \text{ k}\Omega}$$

$$I = 1.065 \mu\text{A}$$

The universal time constant formula also works well for analysing inductive circuits. Let's apply it to our example L/R circuit in the beginning of the chapter:

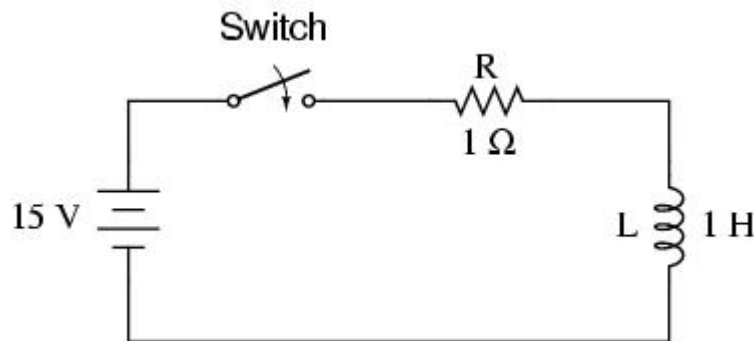

With an inductance of 1 Henry and a series resistance of 1 Ω , our time constant is equal to 1 second:

$$\tau = \frac{L}{R}$$

$$\tau = \frac{1 \text{ H}}{1 \Omega}$$

$$\tau = 1 \text{ second}$$

Because this is an inductive circuit, and we know that inductors oppose change in current, we'll set up our time constant formula for starting and final values of current. If we start with the switch in the open position, the current will be equal to zero, so zero is our starting current value. After the switch has been left closed for a long time, the current will settle out to its final value, equal to the source voltage divided by the total circuit resistance ($I=E/R$), or 15 amps in the case of this circuit.

If we desired to determine the value of current at 3.5 seconds, we would apply the universal time constant formula as such:

$$\text{Change} = (15 \text{ A} - 0 \text{ A}) \left(1 - \frac{1}{e^{3.5/1}}\right)$$

$$\text{Change} = (15 \text{ A} - 0 \text{ A})(0.9698)$$

$$\text{Change} = 14.547 \text{ A}$$

Given the fact that our starting current was zero, this leaves us at a circuit current of 14.547 amps at 3.5 seconds' time.

Determining voltage in an inductive circuit is best accomplished by first figuring circuit current and then calculating voltage drops across resistances to find what's left to drop across the inductor. With only one resistor in our example circuit (having a value of 1 Ω), this is rather easy:

$$E_R = (14.547 \text{ A})(1 \Omega)$$

$$E_R = 14.547 \text{ V}$$

Subtracted from our battery voltage of 15 volts, this leaves 0.453 volts across the inductor at time=3.5 seconds.

$$E_L = E_{\text{battery}} - E_R$$

$$E_L = 15 \text{ V} - 14.547 \text{ V}$$

$$E_L = 0.453 \text{ V}$$

Section Review:

- Universal Time Constant Formula:

Universal Time Constant Formula

$$\text{Change} = (\text{Final}-\text{Start}) \left(1 - \frac{1}{e^{t/\tau}} \right)$$

Where,

Final = Value of calculated variable after infinite time
(its *ultimate* value)

Start = Initial value of calculated variable

e = Euler's number (≈ 2.7182818)

t = Time in seconds

τ = Time constant for circuit in seconds

- To analyse an RC or L/R circuit, follow these steps:
- (1): Determine the time constant for the circuit (RC or L/R).
- (2): Identify the quantity to be calculated (whatever quantity whose change is directly opposed by the reactive component. For capacitors this is voltage; for inductors this is current).
- (3): Determine the starting and final values for that quantity.
- (4): Plug all these values (Final, Start, time, time constant) into the universal time constant formula and solve for *change* in quantity.
- (5): If the starting value was zero, then the actual value at the specified time is equal to the calculated change given by the universal formula. If not, add the change to the starting value to find out where you're at.

4. Why L/R and not LR?

It is often perplexing to new students of electronics why the time-constant calculation for an inductive circuit is different from that of a capacitive circuit. For a resistor-capacitor circuit, the time constant (in seconds) is calculated from the product (multiplication) of resistance in ohms and capacitance in farads: $\tau=RC$. However, for a resistor-inductor circuit, the time constant is calculated from the quotient (division) of inductance in henrys over the resistance in ohms: $\tau=L/R$.

This difference in calculation has a profound impact on the *qualitative* analysis of transient circuit response. Resistor-capacitor circuits respond quicker with low resistance and slower with high resistance; resistor-inductor circuits are just the opposite, responding quicker with high resistance and slower with low resistance. While capacitive circuits seem to present no intuitive trouble for the new student, inductive circuits tend to make less sense.

Key to the understanding of transient circuits is a firm grasp on the concept of energy transfer and the electrical nature of it. Both capacitors and inductors have the ability to store quantities of energy, the capacitor storing energy in the medium of an electric field and the inductor storing energy in the medium of a magnetic field. A capacitor's electrostatic energy storage manifests itself in the tendency to maintain a constant voltage across the terminals. An inductor's electromagnetic energy storage manifests itself in the tendency to maintain a constant current through it.

Let's consider what happens to each of these reactive components in a condition of *discharge*: that is, when energy is being released from the capacitor or inductor to be dissipated in the form of heat by a resistor:

Capacitor and inductor discharge

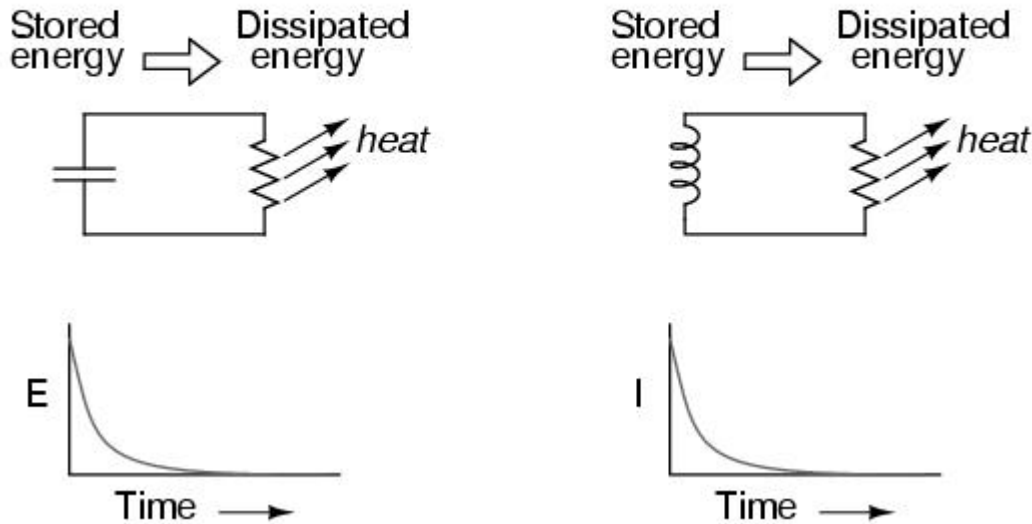

In either case, heat dissipated by the resistor constitutes energy *leaving* the circuit, and as a consequence the reactive component loses its store of energy over time, resulting in a measurable decrease of either voltage (capacitor) or current (inductor) expressed on the graph. The more power dissipated by the resistor, the faster this discharging action will occur, because power is by definition the rate of energy transfer over time.

Therefore, a transient circuit's time constant will be dependent upon the resistance of the circuit. Of course, it is also dependent upon the size (storage capacity) of the reactive component, but since the relationship of resistance to time constant is the issue of this section, we'll focus on the effects of resistance alone. A circuit's time constant will be less (faster discharging rate) if the resistance value is such that it maximizes power dissipation (rate of energy transfer into heat). For a capacitive circuit where stored energy manifests itself in the form of a voltage, this means the resistor must have a low resistance value so as to maximize current for any given amount of voltage (given voltage times high current equals high power). For an inductive circuit where stored energy manifests itself in the form of a current, this means the resistor must have a high resistance value so as to maximize voltage drop for any given amount of current (given current times high voltage equals high power).